

ELECTRO-PNEUMATIC POSITIONER TZIDC

DESCRIPTION

The ADCATrol TZIDC is an electronically configurable positioner with communication capabilities designed for mounting to pneumatic linear or rotary actuators. It features a small and compact design, a modular construction, and an excellent cost-performance ratio.

Fully automatic determination of the control parameters and adaptation to the final control element yield considerable time savings and an optimal control behaviour.



MAIN FEATURES

- Low operating cost.
- Compact and flexible design.
- Easy to commission with user-friendly interface.
- Increased shock and vibration resistance with gearless sensor activation.
- Reliable and efficient, with integrated maintenance-friendly air filters.
- Automatic adjustment of control parameters during operation.
- Integrated mechanical position indicator.
- With HART, Profibus PA or FOUNDATION Fieldbus-H1.
- Wide operating temperature range (- 40 ° to 85 °C).
- Mounting onto any linear or rotary actuator.
- Single or double acting.
- ATEX, FM, CSA, GOST AND IECEx approvals.
- For SIL2 safety loops.

OPTIONS AND ACCESSORIES

- Module for analog position feedback.
- Digital position feedback with 24 V microswitches.
- Positioner with remote sensor.
- Attachment kit for linear actuators acc. to DIN/IEC 534/NAMUR and rotary actuators acc. to VDI/VDE 3845.
- Connection manifold with gauges.
- PC adapters for communication.
- PC software for remote configuration and operation.

DIMENSIONS (mm)

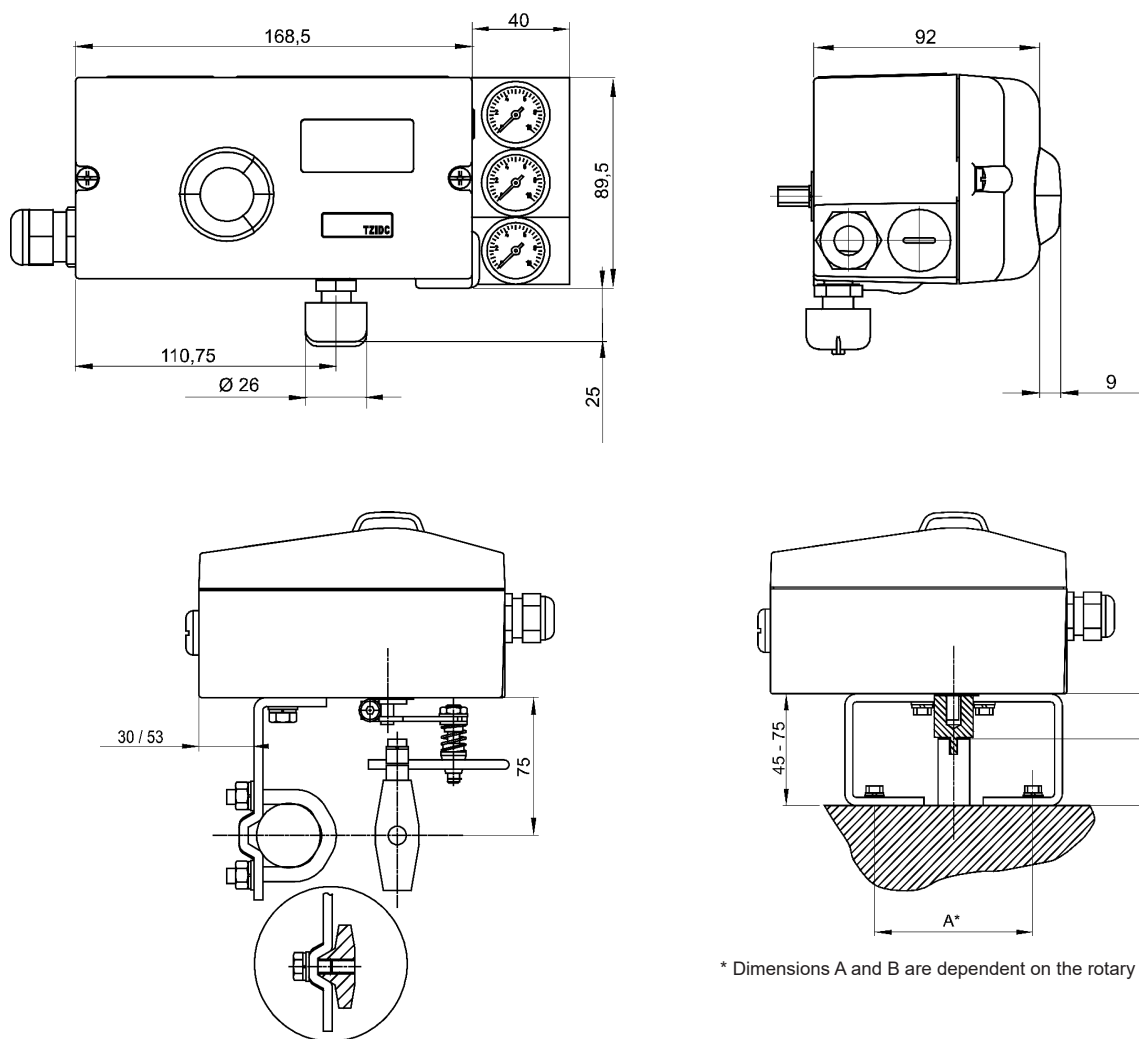

* Dimensions A and B are dependent on the rotary actuator.

TECHNICAL DATA

GENERAL	
Material / IP rating	Aluminum with $\leq 0.1\%$ copper, protection class IP 65 (optional IP 66) / NEMA 4X
Surface	Electrostatic dipping varnish with epoxy resin, stove-hardened.
Electrical connections	Screw terminals: Max. 1.0 mm ² for options Max. 2.5 mm ² for bus connector
Connections	Cable: thread M20 x 1,5, air pipe: thread G 1/4 ;
Weight	1,7 kg (3,75 lb)
Mounting orientation	Any

DIRECTIVES AND COMMUNICATION	
Directives	Compliant with: - EMC directive 2004/108/EC from 12/2004 - EC Directive for CE conformity marking
Communication	- HART [®] protocol 5.9 as standard, optionally HART [®] protocol 7.4; - Profibus PA; - FOUNDATION Fieldbus H1; - Local connector for LCI (not in explosion protection area) - HART communication via 20 mA signal line with (optional) FSK modem

TRAVEL	
Rotation angle	
Measuring range	270°
Working range (Fig.1)	Linear actuators - min. 25°, max. 45°
	Rotary actuators - min. 25°, max. <270°
Travel limit	Min. and max. limits, freely configurable between 0 ... 100 % of total travel (min. range > 20 %)
Travel prolongation	Range of 0 ... 200 s, separately for each direction
Dead band time limit	Setting range 0 ... 200 s (monitoring parameter for control until the deviation reaches the dead band)

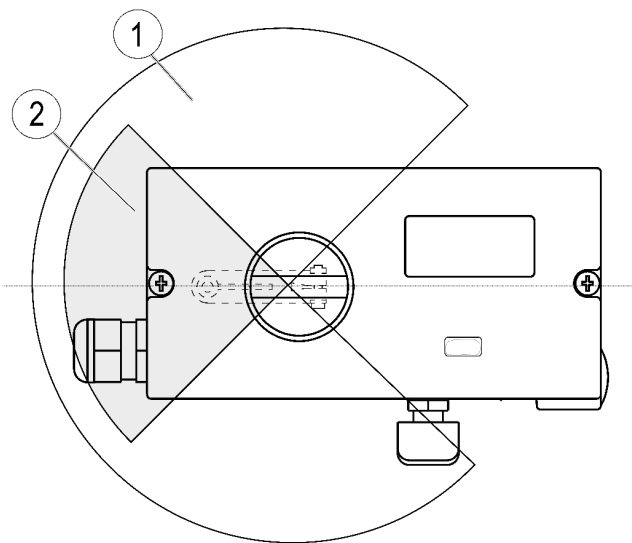

- ① Measuring range
- ② Operating range

Fig. 1 – Measuring and operating ranges

AIR SUPPLY *	
Instrument air	
Purity:	Max. particle size = 5 µm; Max. particle density = 5 mg / m³
Oil content:	Max. concentration = 1 mg / m³
Pressure dew point:	10 K below operating temp
Supply pressure **	1.4 to 6 bar (20 to 90 psi)
Air consumption ***	< 0.03 kg/h / 0.015 scfm

* Free of oil, water and dust, according to DIN/ISO 8573-1. Pollution and oil content according to Class 3.

** Do not exceed the maximum operating pressure of the actuator!

*** Independent of supply pressure.

TRANSMISSION DATA AND CONTRIBUTING FACTORS	
Output Y1	
Increasing	Increasing setpoint signal 0...100% Increasing pressure at output
Decreasing	Increasing setpoint signal 0...100% Decreasing pressure at output
Action (setpoint signal)	
Increasing	Signal 4 ... 20 mA = Position 0 ... 100%
Decreasing	Signal 20 ... 4 mA = Position 0 ... 100%
Characteristic curve (travel = f {setpoint signal}) *	
Deviation	≤ 0.5 %
Tolerance band	0,3 ... 10 %, adjustable
Dead band	0,1 ... 10 %, adjustable
Resolution (A/D conversion)	> 16,000 steps
Sample rate	20 ms
Influence of ambient temp.	≤ 0.5 % per 10 K
Reference temperature	20 °C
Influence of vibration	≤ 1 % to 10 g and 80 Hz
Seismic vibration	Meets requirements of DIN/IEC 68-3-3 Class III for strong and strongest earthquakes

* Linear, equal percentage 1:25 or 1:50 or 25:1 or 50:1 and freely configurable with 20 reference points

AMBIENT CONDITIONS	
Ambient temperature	
During operation, storage and transport	- 40 °C to 85 °C
	- 25 °C to 85 °C - 40 °C to 100 °C *
Relative humidity	
Operation (closed housing and air supply switched on)	95 % (annual average), condensation permissible
Transport and storage	75% (annual average), non-condensing.

* Increased temperature range only with TZIDC Remote Sensor.

SAFETY INTEGRITY LEVEL				
TZIDC meets the following requirements:	- Functional safety acc. to IEC 61508			
	- Explosion protection (depending on the model)			
- Electromagnetic compatibility acc. to EN 61000				
Without the input signal, the pneumatic module in the positioner vents the drive and the installed spring in it moves the valve to a predetermined end position (OPEN or CLOSED).				
SIL specific safety-related characteristics				
Device	SFF	PFDav	$\lambda_{dd} + \lambda_s$	λ_{du}
TZIDC with supply current 0 mA	94%	1.76×10^{-4}	651 FIT	40 FIT

Remarks: Applies to applications with single-acting and depressurizing pneumatics.

ELECTRICAL CONNECTIONS

Positioner / TZIDC control unit connections

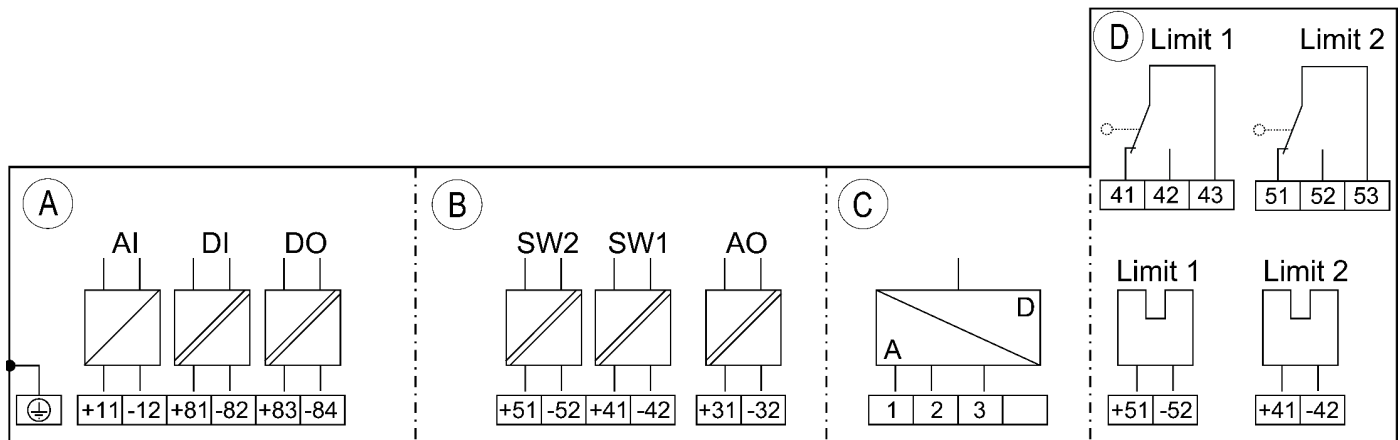

TERMINALS	
TERMINAL	DESCRIPTION
+11 / -12	Analog input
+81 / -82	Binary input DI
+83 / -84	Binary output DO2
+51 / -52	Digital feedback SW1 (optional module)
+41 / -42	Digital feedback SW2 (optional module)
+31 / -32	Analog feedback AO (optional module)
1 / 2 / 3	TZIDC remote sensor *
+51 / -52	Limit switch Limit 1 with proximity switch (optional)
+41 / -42	Limit switch Limit 2 with proximity switch (optional)
41 / 42 / 43	Limit switch Limit 1 with microswitch (optional)
51 / 52 / 53	Limit switch Limit 2 with microswitch (optional)

* Only for options TZIDC Remote Sensor or TZIDC for remote position sensor.

Remarks: The TZIDC can be fitted either with proximity switches or microswitches as limit switches. It is not possible to combine both variants. For the version TZIDC Control Unit with TZIDC Remote Sensor, the limit switches are located in the TZIDC Remote Sensor.

Binary output DO *	
Terminals	+83 / -84
Supply voltage	5 to 11 V DC (Control circuit in accordance with DIN 19234 / NAMUR)
Output "logical 0"	> 0,35 mA to < 1,2 mA
Output "logical 1"	> 2,1 mA
Direction of action	Configurable "logical 0" or "logical 1"

* Output configurable as alarm output by software.

ANALOG INPUT SIGNAL	
Set point signal (two-wire technology)	
Terminals	+11 / -12
Nominal operating range	4 to 20 mA
Split range config.	between 20 to 100% of the nominal operating range can be parameterized
Operating range limits	3.8 to 50 mA
Load voltage	9.7 V at 20 mA
Impedance	485 Ω at 20 mA

DIGITAL INPUT

Input for the following functions:

- no function
- move to 0%
- move to 100%
- hold previous position
- block local configuration
- block local configuration and operation
- block any access (local or via PC)

Binary input DI	
Terminals	+81 / -82
Supply voltage	24 V DC (12 to 30 V DC)
Input "logical 0"	0 to 55 V DC
Input "logical 1"	11 to 30 V DC
Input current	Maximum 4 mA

Optional modules

MODULE FOR ANALOG FEEDBACK AO *	
Terminals	+31 / -32
Signal range	4 to 20 mA (split ranges can be parameterized)
Supply voltage (two-wire technology)	24 V DC (11 to 30 V DC)
Characteristic curve	Rising or falling (configurable)
Deviation	< 1 %

Remarks: Without any signal from the positioner (e.g. "no power", "initializing", or in the event of an error), the module sets the output to >20 mA (alarm level).

MODULE FOR DIGITAL FEEDBACK SW1, SW2 *	
Terminals	+41 / -42; +51 / -52
Supply voltage	5 to 11 V DC (Control circuit in accordance with DIN 19234 / NAMUR)
Output "logical 0"	< 1.2 mA
Output "logical 1"	> 2.1 mA
Direction of action	Configurable "logical 0" or "logical 1"
Description	2 software switches for binary position feedback (position adjustable within the range of 0 to 100 %, ranges cannot overlap).

* The module for analog feedback and the module for digital feedback have separate slots and can be used together.

Assembly kits for limit monitor: Two proximity switches or microswitches for independent signaling of the actuator position, switching points are adjustable between 0 to 100%

LIMIT MONITOR WITH PROXIMITY SWITCHES LIMIT 1, 2		
Terminals	+41 / -42; +51 / -52	
Supply voltage	5 to 11 V DC (Control circuit in accordance with DIN 19234 / NAMUR)	
Direction of action	Metal tag in proximity switch	Metal tag outside proximity switch
Type SJ2-SN (NC; log 1)	< 1.2 mA	> 2.1 mA

LIMIT MONITOR WITH 24V MICROSWITCHES LIMIT 1, 2	
Terminals	+41 / -42; +51 / -52
Supply voltage	Maximum 24 V AC/DC (Control circuit in accordance with DIN 19234 / NAMUR)
Load rating	Maximum 2 A
Contact surface	10 µm Gold (AU)

TZIDC Remote sensor electrical connections

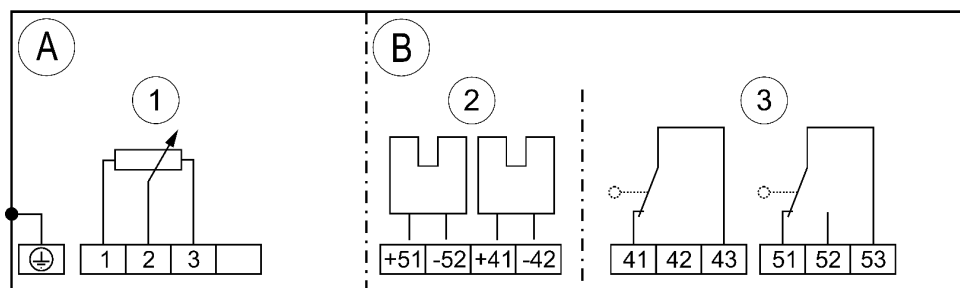

- A** Basic device
- B** Options
- 1** Position sensor
- 2** Limit monitor with proximity switches (optional)
- 3** Limit monitor with microswitches (optional)

TERMINALS	
TERMINAL	DESCRIPTION / CONNECTION
1 / 2 / 3	TZIDC control unit
+51 / -52	Proximity switches Limit 1 (optional)
+41 / -42	Proximity switches Limit 2 (optional)
41 / 42 / 43	Microswitches Limit 1 (optional)
51 / 52 / 53	Microswitches Limit 2 (optional)

Remarks: The TZIDC Remote Sensor can be fitted either with proximity switches or microswitches as limit switches. It is not possible to combine both variants.

Remarks:

For full product specifications, including requirements for use in potentially explosive atmospheres, different communication protocols (Profibus PA and FOUNDATION Fieldbus-H1) and others, please consult.